

FUA100A

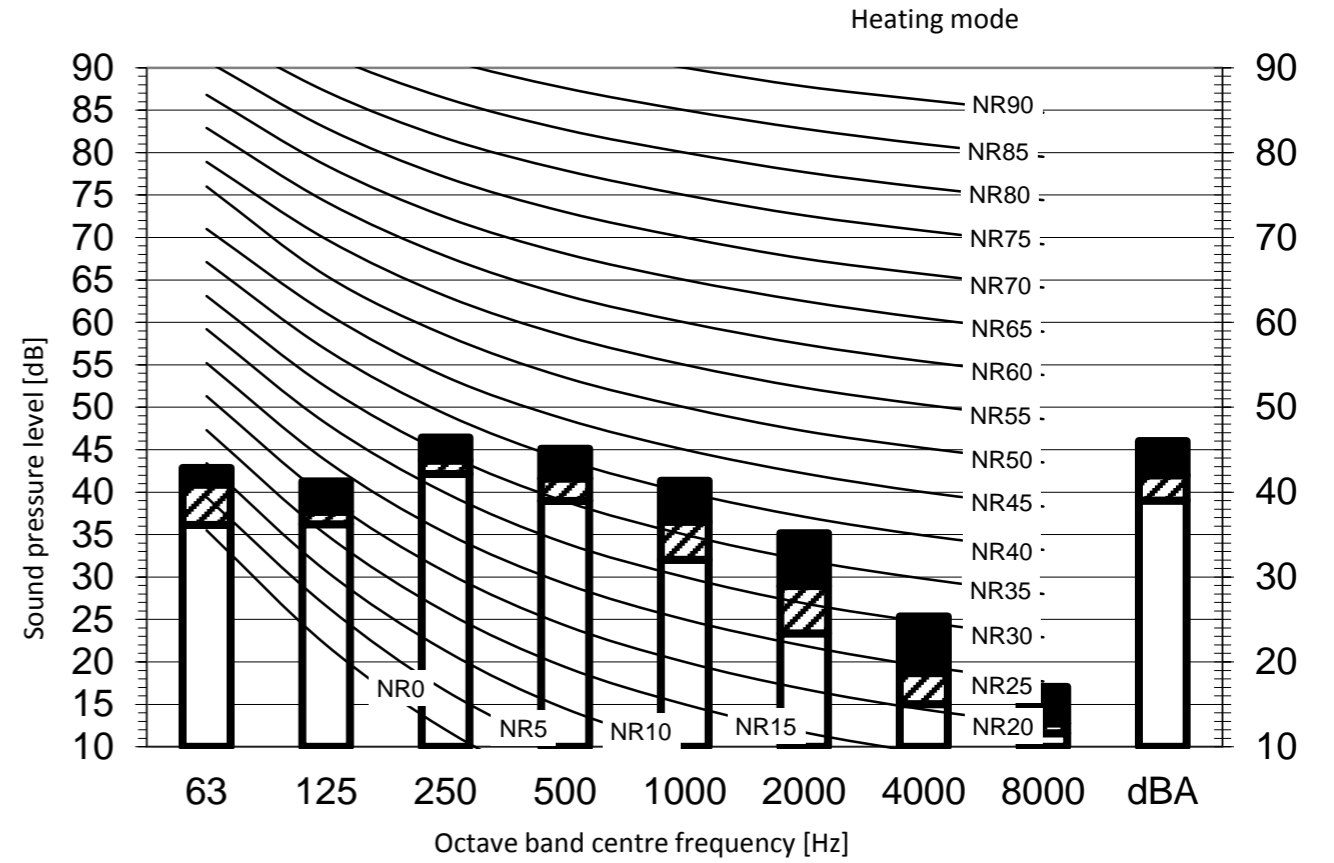
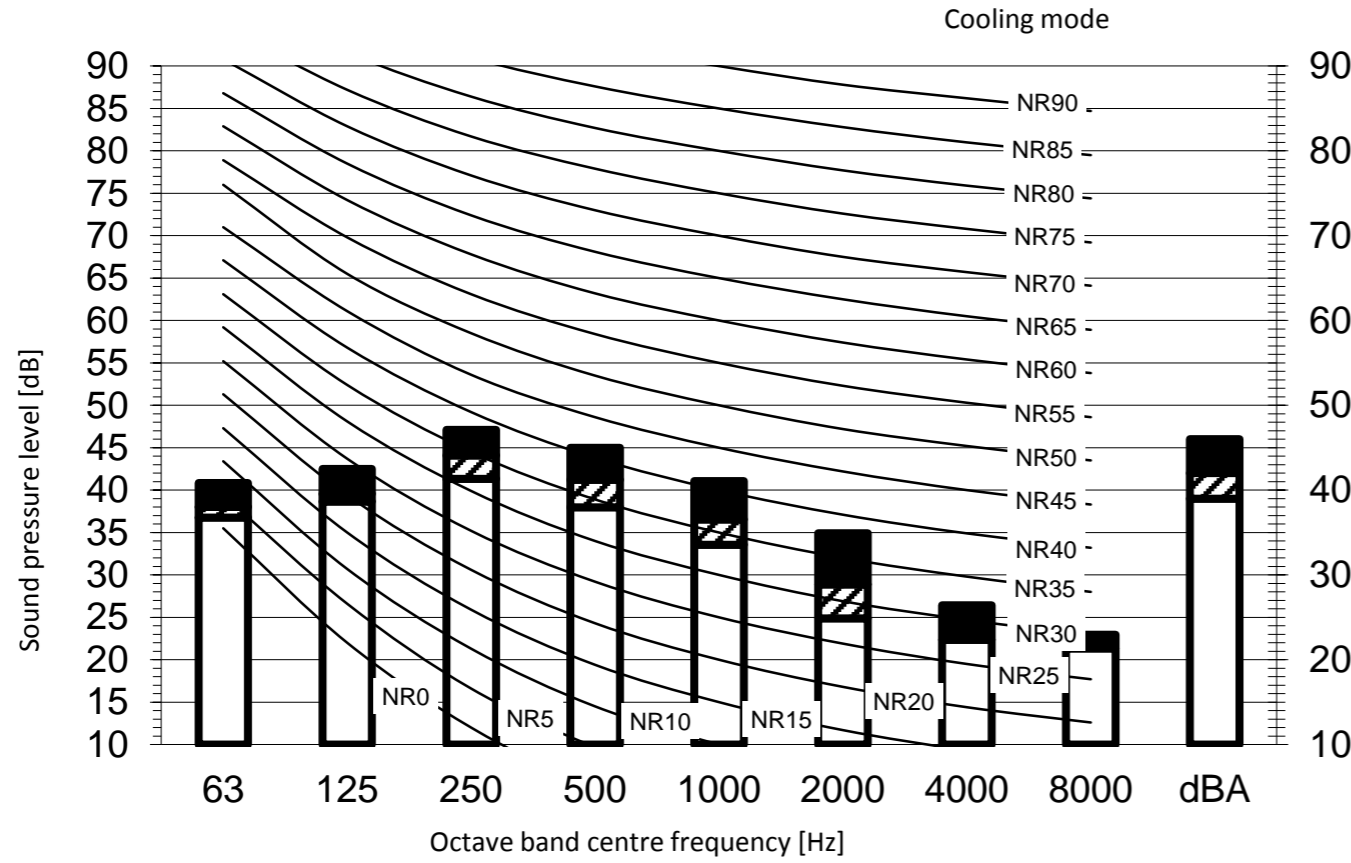

Legend

dBA = A-weighted sound pressure level (A scale according to IEC).

A Scale Fan speed

- B High
- C Medium
- D Low

Cooling		Total dB	
A	B	C	D
dBA	46	42	39

Heating		Total dB	
A	B	C	D
dBA	46	42	39

Location of microphone

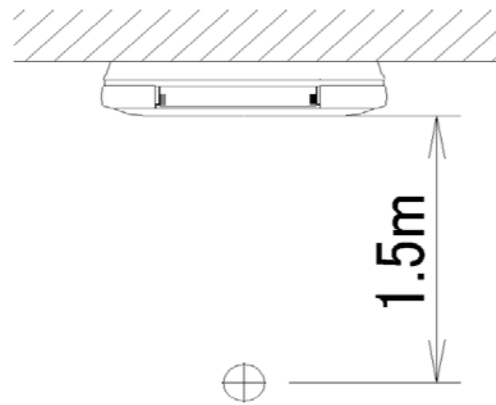

Notes

- 1 . Operating conditions: power source 220-240 V/220 V 50/60 Hz; JIS standard
- 2 . Background noise already taken into account.
- 3 . Operating noise varies depending on operation and ambient conditions.
- 4 . The operation noise measuring method is in accordance with JISC9612.
- 5 . Measuring location: anechoic chamber