

**FHA35-71A9**  
**FHA100-140A**

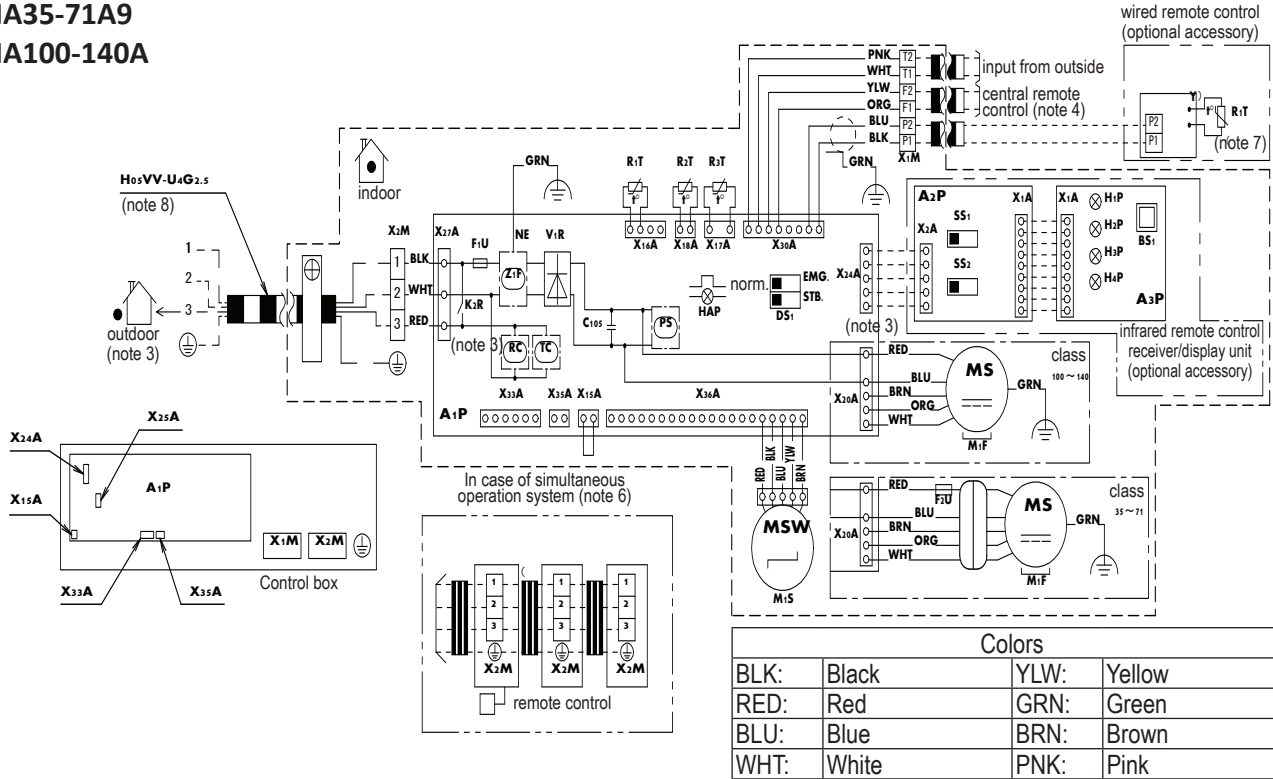

Indoor unit		TC	Signal transmission circuit
A1P	Printed circuit board	Wired remote control	
C105	Capacitor (M1F)	R1T	Thermistor (air)
F1U	Fuse (F, 5A, 250V)	Infrared remote control (receiver/display unit)	
F2U	Fuse (F, 4A, 500V)	A2P	Printed circuit board
DS1	Dip switch on PCB	A3P	Printed circuit board
HAP	Flashing lamp (service monitor: green)	BS1	Push button (on/off)
K2R	Magnetic relay	H1P	Pilot lamp (on: red)
M1F	Motor (indoor fan)	H2P	Pilot lamp (timer: green)
M1S	Motor (swing blade)	H3P	Pilot lamp (filter sign: red)
R1T	Thermistor (air)	H4P	Pilot lamp (defost: orange)
R2T-R3T	Thermistor (coil)	SS1	Selector switch (main/sub)
V1R	Diode bridge	SS2	Selector switch (wireless address set)
X1M	Terminal block	Connector for optional parts	
X2M	Terminal block	X15A	Connector (floatins switch)
Z1F	Noise filter	X24A	Connector (infrared remote control)
PS	Power supply circuit	X33A	Connector (adapter for wiring)
RC	Signal receiver unit	X35A	Connector (power supply for adapter)

**NOTES**

- : terminal block, □○□: connector, ---■---: field wiring, □○□: short circuit connector
- In case of simultaneous operation indoor unit system, see the indoor unit wiring only. For the detail, see wiring diagram attached to outdoor unit.
- In case using central remote control, connect it to the unit in accordance with the attached installation manual.
- X15A, X25A are connected when the drain pump kit is being used.
- In case of simultaneous operation system, connected quantity of the indoor units varies according to the connection outdoor unit. Confirm technical guide and catalogue, etc. before connecting.
- In case of main/sub changeover see the installation manual attached to remote control.
- Shows only in case of protection piping, use H07RN-F in case of no protection.