

RXM42-50M9

Wiring diagram

For the power requirements, refer to the nameplate.

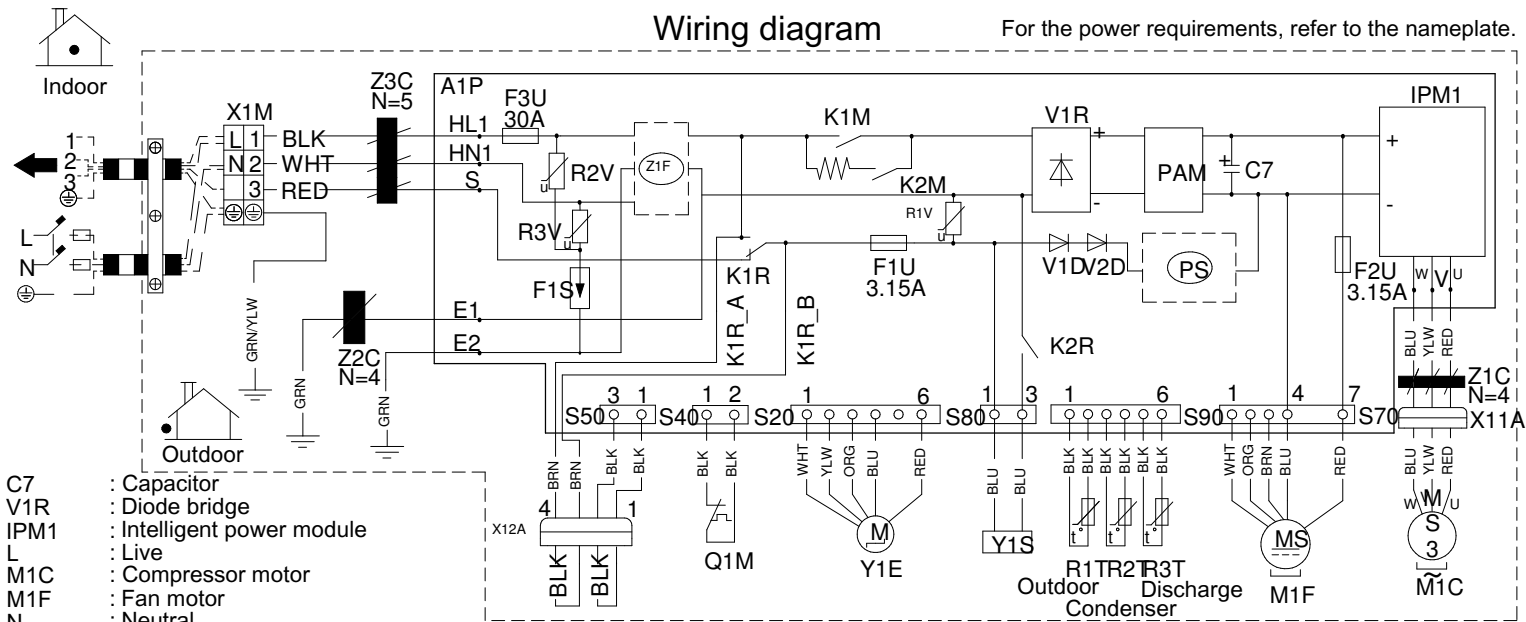

- C7 : Capacitor
- V1R : Diode bridge
- IPM1 : Intelligent power module
- L : Live
- M1C : Compressor motor
- M1F : Fan motor
- N : Neutral
- PAM : Pulse-amplitude modulation
- A1P : Printed circuit board
- PS : Switching power supply
- Q1M : Self-operating thermal protector (break)
- F1S : Lightning arrester
- X1M : Terminal strip
- Y1E : Electronic expansion valve coil
- Y1S : Reversing solenoid valve coil
- Z1F : Noise filter
- V1D, V2D : Diode

- F1U, F2U, F3U : Fuse
- K1M, K2M, K1R, K2R : Magnetic relay
- R1T, R2T, R3T : Thermistor
- S20, S40, S50, S70, S80 : Connector
- S90, X11A, X12A : Connector
- R1V, R2V, R3V : Varistor
- Z1C, Z2C, Z3C : Ferrite core
- HL1, HN1, S, E1, E2 : Connection
- K1R_A, K1R_B : Connection

- BLK : Black
- WHT : White
- BRN : Brown
- RED : Red
- GRN : Green
- YLW : Yellow
- ORG : Orange
- BLU : Blue
- ⊕ : Protective earth
- ⊖ : Earth

Field wiring

3D108900-1A

NOTES:

1. Size: length 105x width 185.
2. Refer to purchasing specification AS303002 unless otherwise specified.

3D108900A