

# RXM20-35N9

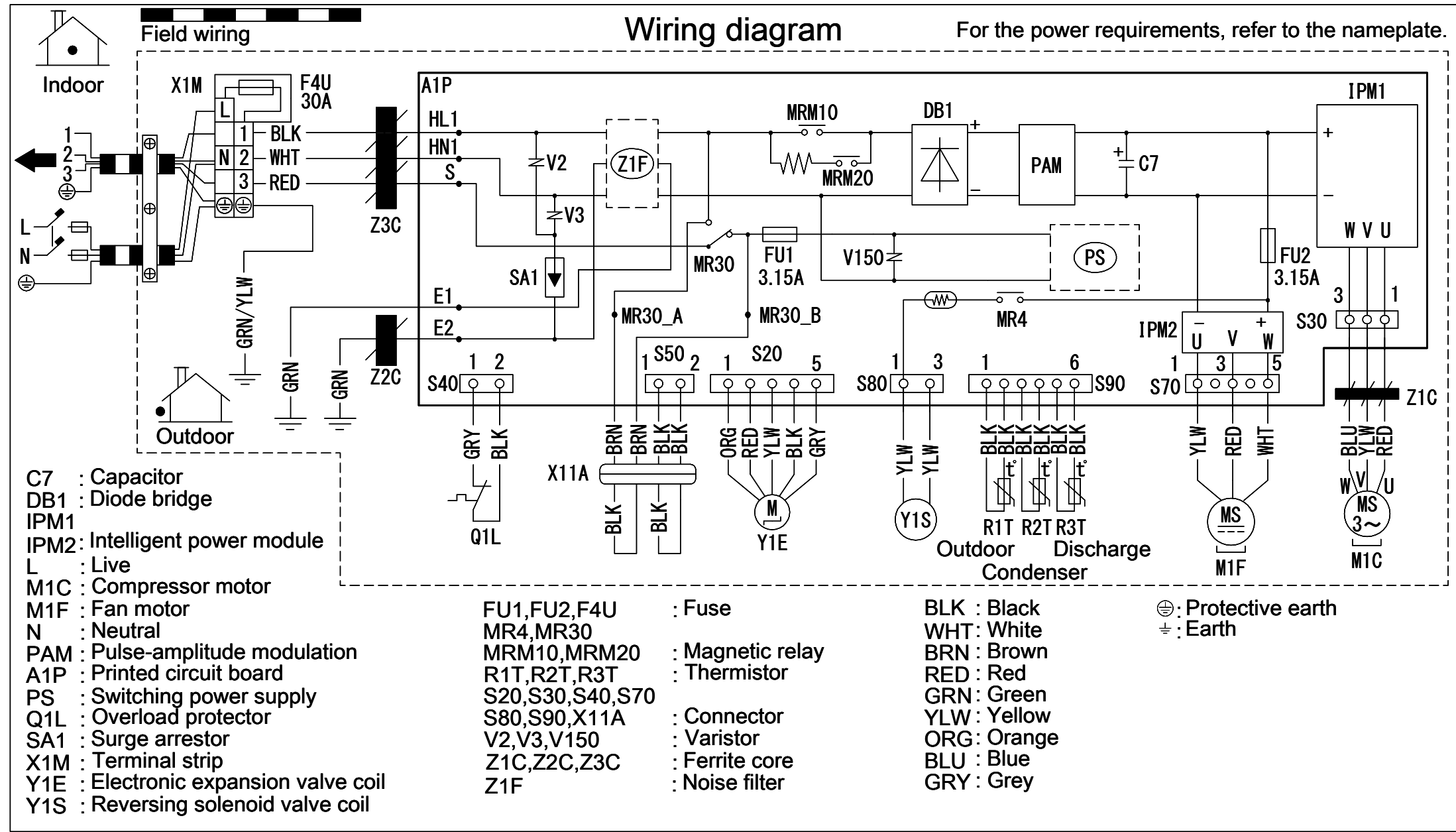

## Notes

Size: 140 x 80

Refer to purchasing specification AS303002, unless otherwise specified.

**4D120154**