

# RXM20-35M9

## Wiring diagram

For the power requirements, refer to the nameplate.

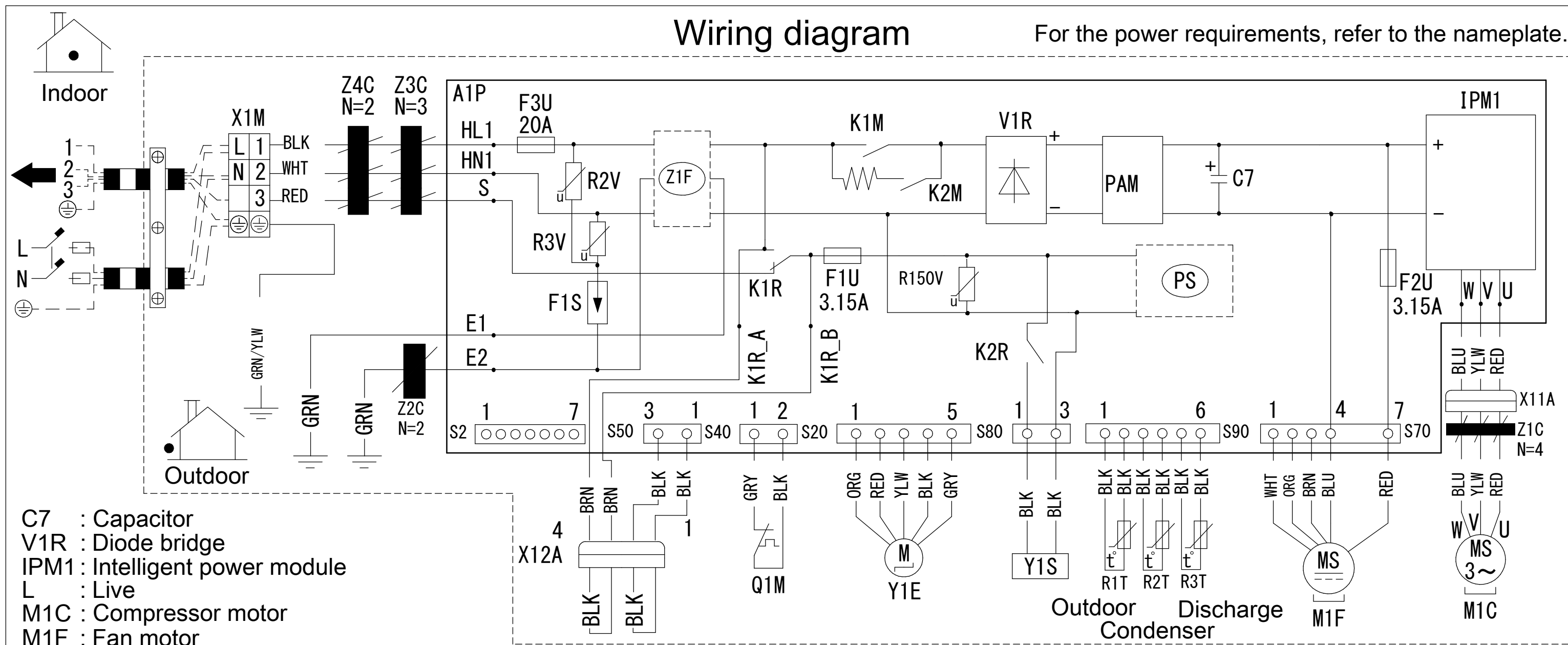

- C7 : Capacitor
- V1R : Diode bridge
- IPM1 : Intelligent power module
- L : Live
- M1C : Compressor motor
- M1F : Fan motor
- N : Neutral
- PAM : Pulse-amplitude modulation
- A1P : Printed circuit board
- PS : Switching power supply
- Q1M : Self-operating thermal protector (break)
- F1S : Lightning arrestor
- X1M : Terminal strip
- Y1E : Electronic expansion valve coil
- Y1S : Reversing solenoid valve coil
- Z1F : Noise filter

- F1U,F2U,F3U : Fuse
- K1M,K2M,K1R,K2R : Magnetic relay
- R1T,R2T,R3T : Thermistor
- S20,S40,S50,S70,S80 : Connector
- S90,X11A,X12A,S2 : Connector
- R2V,R3V,R150V : Varistor
- Z1C,Z2C,Z3C,Z4C : Ferrite core
- HL1,HN1,S,E1,E2 : Connection
- K1R\_A,K1R\_B : Connection

- BLK : Black
- WHT : White
- BRN : Brown
- RED : Red
- GRN : Green
- YLW : Yellow
- ORG : Orange
- BLU : Blue
- GRY : Grey

- ⊕ : Protective earth
  - ⊖ : Earth
- Field wiring

3D108899-1

### NOTES:

1. Size: 140 x 80
2. Refer to purchasing specification AS303002, unless otherwise specified.